



Cambridge International AS & A Level

DESIGN & TECHNOLOGY

9705/11

Paper 1

October/November 2022

3 hours



You must answer on the answer booklet/paper.

You will need: Answer booklet/A4 paper Coloured pencils
A3 drawing paper (2 sheets) Extra sheets of A3 drawing paper if needed
A range of design drawing equipment

INSTRUCTIONS

- Answer **three** questions in total:
 - Section A: answer **one** question on the answer booklet/A4 paper provided.
 - Section B: answer **one** question on the answer booklet/A4 paper provided.
 - Section C: answer **one** question on A3 drawing paper. Use both sides of the paper.
- You may request additional sheets of A3 drawing paper, but only if you have used up both sides of each of the 2 sheets provided.
- If you have been given an answer booklet, follow the instructions on the front cover of the answer booklet.
- Use a black or dark blue pen.
- Write your name, centre number and candidate number on all the work you hand in.
- Do **not** use an erasable pen or correction fluid.
- You may use an HB pencil, or coloured pencils as appropriate, for any diagrams, graphs or rough working.
- At the end of the examination, fasten all your work together. Do **not** use staples, paper clips or glue.

INFORMATION

- The total mark for this paper is 120.
- The number of marks for each question or part question is shown in brackets [].
- All dimensions are in millimetres.

This document has **12** pages. Any blank pages are indicated.

Section A

Answer **one** question from this section on the Answer Booklet/A4 paper provided.

- 1 Fig. 1.1 gives details of a balancing game which is to be made in a school workshop.

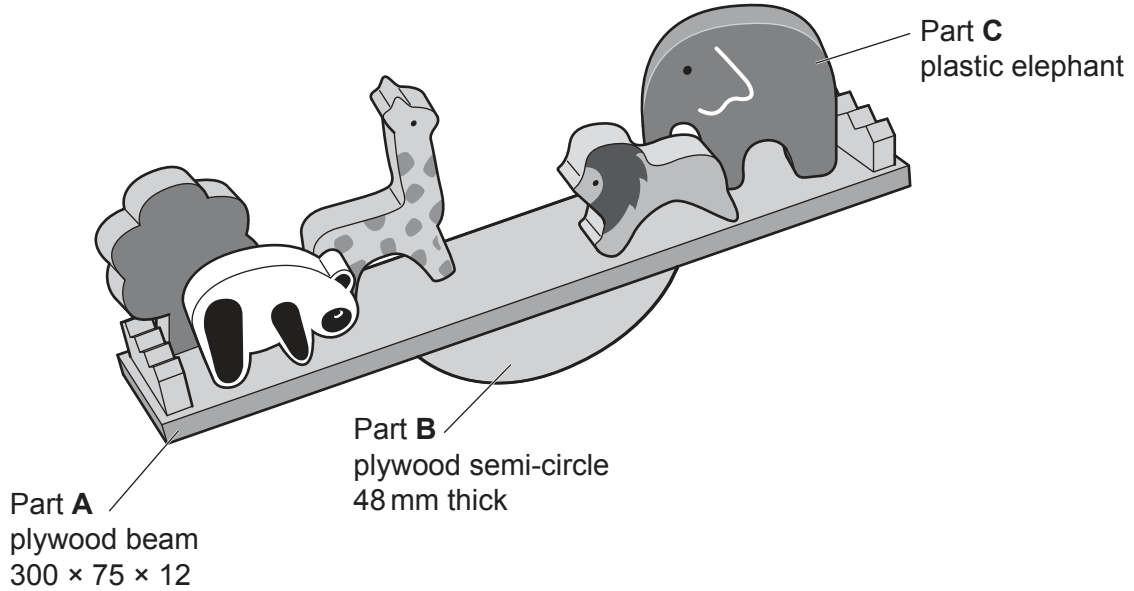

Fig. 1.1

- (a) State **two** reasons why plywood is a suitable material for Part A. [2]
- (b) Use notes and sketches to describe:
- (i) how Part B could be marked out and cut to shape [6]
 - (ii) a temporary method of joining Part A and Part B. [6]
- You must give details about the tools, equipment and processes involved and the safety precautions that have to be undertaken at each stage.
- (c) Use notes and sketches to show a method of making a batch of 500 of Part C, the plastic elephant. [6]

- 2 Fig. 2.1 gives details of a lampshade which is to be made in a school workshop. The polypropylene shade wraps around the mild steel frame.

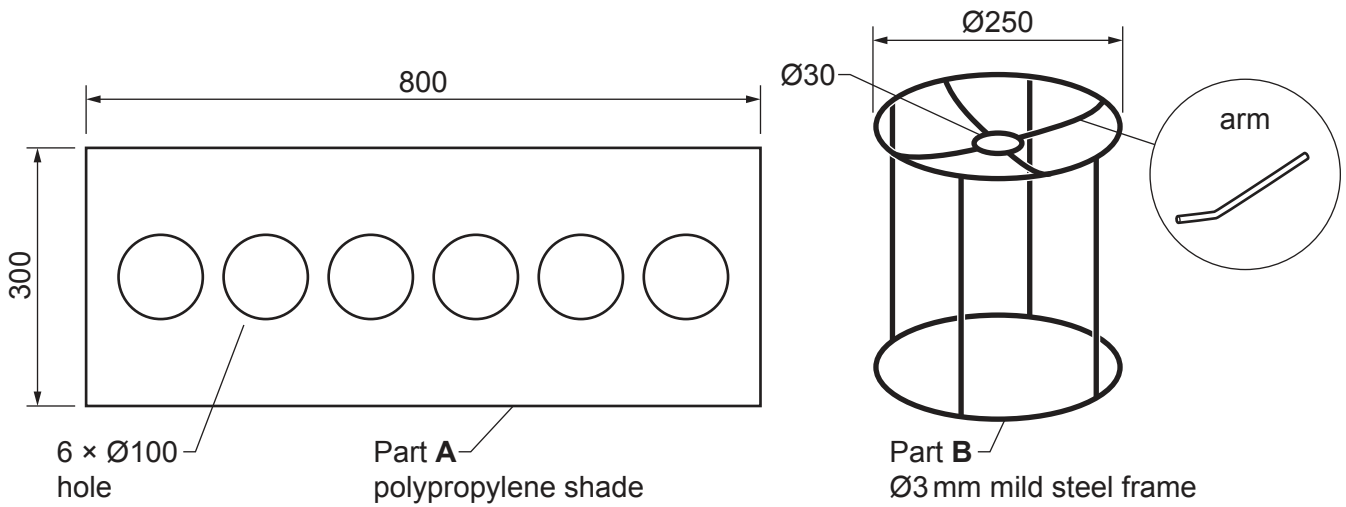

Fig. 2.1

- (a) State **two** properties of polypropylene that make it suitable for the shade. [2]
- (b) Use notes and sketches to describe:
- (i) how Part **A** could be marked out and cut to shape [6]
 - (ii) how Part **A** could be fitted to Part **B** [6]
 - (iii) how the four identical **arms** of Part **B** could be made. [6]

You must give details about the tools, equipment and processes involved and the safety precautions that have to be undertaken at each stage.

- 3 Fig. 3.1 gives details of a battery operated steady hand game which is to be made in a school workshop. A buzzer sounds if the loop on the handle touches Part A.

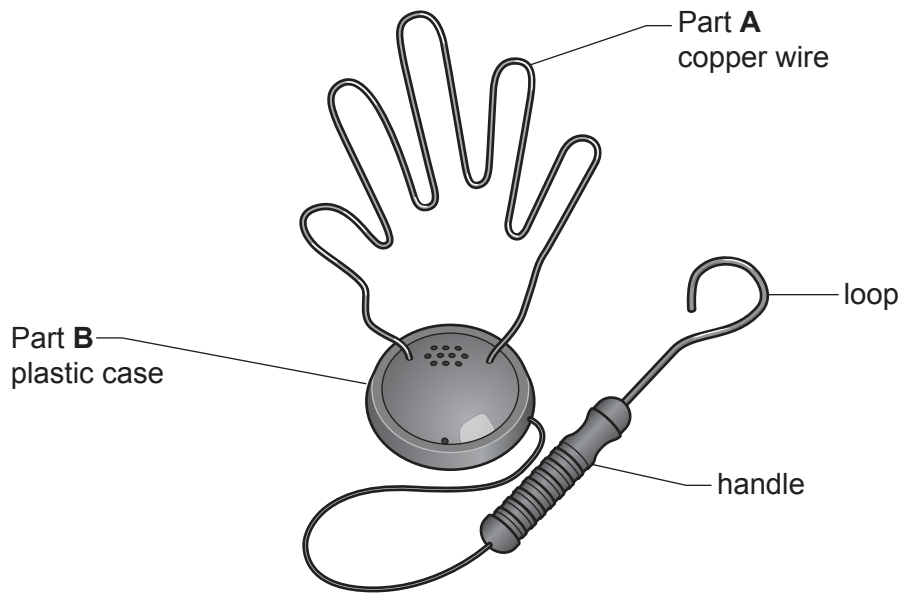

Fig. 3.1

- (a) Give **two** reasons why copper wire is suitable for Part A. [2]
- (b) Use notes and sketches to:
- (i) show the circuit diagram for the steady hand game [6]
- (ii) describe a method used to join the components in the circuit contained in Part B. [6]
- You must give details about the tools, equipment and processes involved and the safety precautions that have to be undertaken at each stage.
- (c) Use notes and sketches to show a method of making Part B, the plastic case. [6]

Section B

Answer **one** question from this section on the Answer Booklet/A4 paper provided.

- 4 Fig. 4.1 gives details of a set of steps to be used around the home.

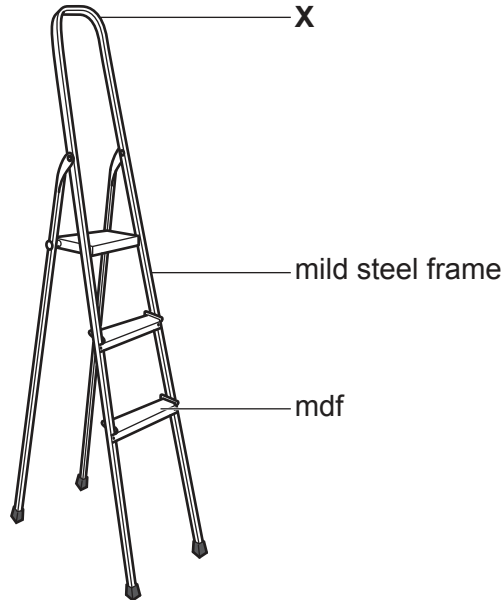

Fig. 4.1

- (a) Explain the function of the design feature shown at **X**. [2]
- (b) Identify and describe **two** problems with the set of steps. [4]
- (c) Use notes and sketches to explain how the set of steps would need to be changed to overcome the **two** problems you have identified in **part (b)**. [6]
- (d) Discuss why many pieces of equipment, such as the set of steps, are designed to be folded or dismantled. Your answer should:
- (i) analyse the given situation and identify **three** relevant issues raised by the question [3]
 - (ii) explain why you consider these issues to be relevant [3]
 - (iii) contain specific examples/evidence to support your conclusions. [2]

- 5 Fig. 5.1 gives details of the packaging for a table tennis bat. The development (net) is folded into shape to make the packaging.

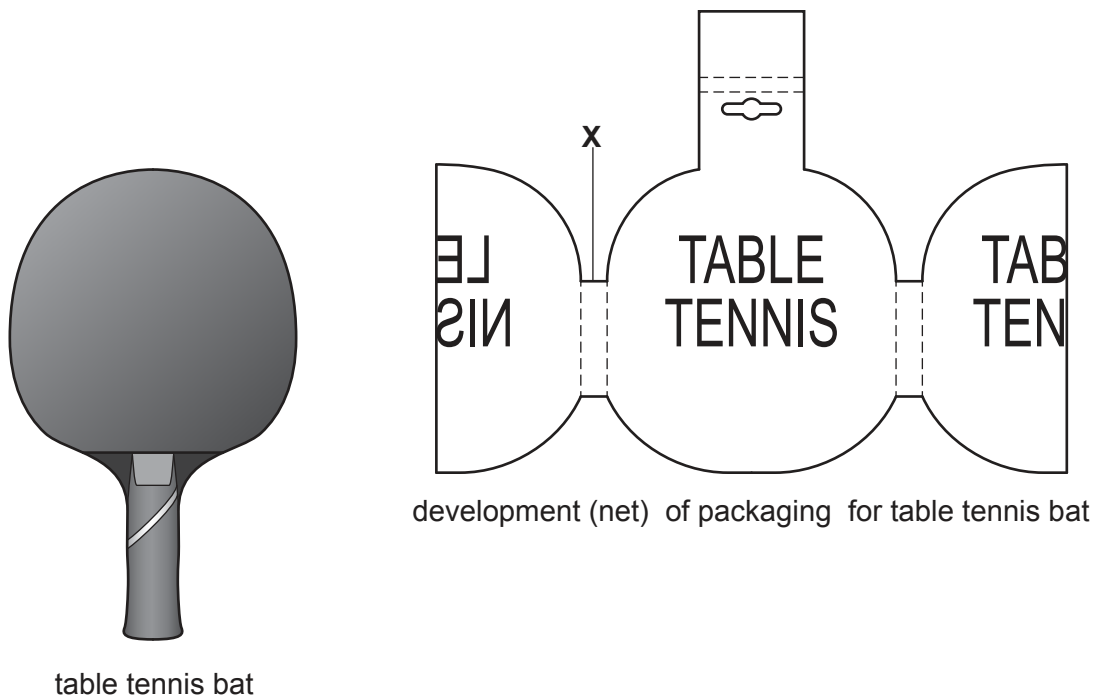

Fig. 5.1

- (a) Explain the function of the design feature shown at X. [2]
- (b) Identify and describe **two** problems with the **development (net)** required to make the packaging for the table tennis bat. [4]
- (c) Use notes and sketches to explain how the development (net) would need to be changed to overcome the **two** problems you have identified in **part (b)**. [6]
- (d) Discuss why many card products, such as the packaging for the table tennis bat, are made from recycled materials. Your answer should:
- (i) analyse the given situation and identify **three** relevant issues raised by the question [3]
 - (ii) explain why you consider these issues to be relevant [3]
 - (iii) contain specific examples/evidence to support your conclusions. [2]

6 Fig. 6.1 gives details of an electric extension cable for use with portable power tools.

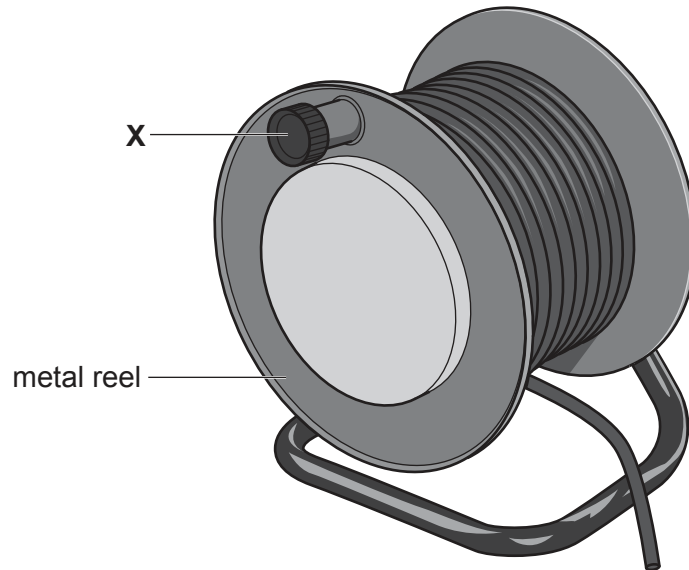

Fig. 6.1

- (a) Explain the function of the design feature shown at **X**. [2]
- (b) Identify and describe **two** problems with the electric extension cable. [4]
- (c) Use notes and sketches to explain how the extension cable would need to be changed to overcome the **two** problems you have identified in **part (b)**. [6]
- (d) Discuss why many electrical products, such as portable power tools, use a rechargeable battery as a power source rather than mains electricity. Your answer should:
- (i) analyse the given situation and identify **three** relevant issues raised by the question [3]
 - (ii) explain why you consider these issues to be relevant [3]
 - (iii) contain specific examples/evidence to support your conclusions. [2]

Section C

Answer **one** question from this section on the plain A3 paper provided.

You are provided with two sheets of plain A3 paper. You should use **both** sides of the paper. **Each** of the four parts (a) – (d) of the question you choose to answer should take up one side of paper.

When you are asked to **develop** a design you must show, using notes and sketches, the development and evaluation of a **range** of ideas into a single design solution. The design proposal should be annotated to give details about materials, joining methods and important sizes.

- 7 Fig. 7.1 shows an indoor climbing frame and a pair of children's shoes. Children must remove their shoes when using the climbing frame.

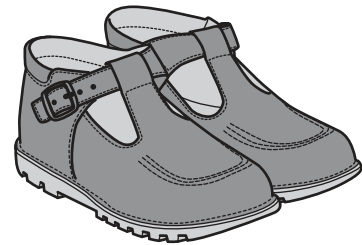
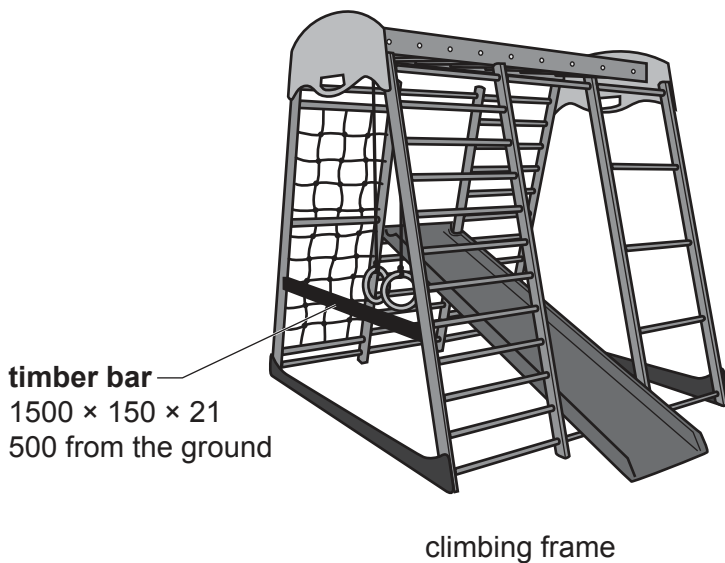

pair of children's shoes
approximate size:
140 long × 70 wide × 80 high

Fig. 7.1

- (a) Use notes and sketches to **develop** a design for a device for holding a pair of shoes together and making them easily identifiable whilst in storage. [20]
- (b) Use notes and sketches to **develop** a design for a shoe storage system that can hold eight pairs of shoes. [20]
- (c) Use notes and sketches to **develop** a design for a bracket for attaching the shoe storage system designed in **part (b)** to the timber bar on the climbing frame. [20]
- (d) Produce a pictorial (3D) rendered drawing of the shoe storage system which shows all of the features that you have designed in **parts (a) – (c)**. Do **not** include the climbing frame. [20]

8 Fig. 8.1 shows a sheet of modelling material, such as foamboard, and a sports watch.

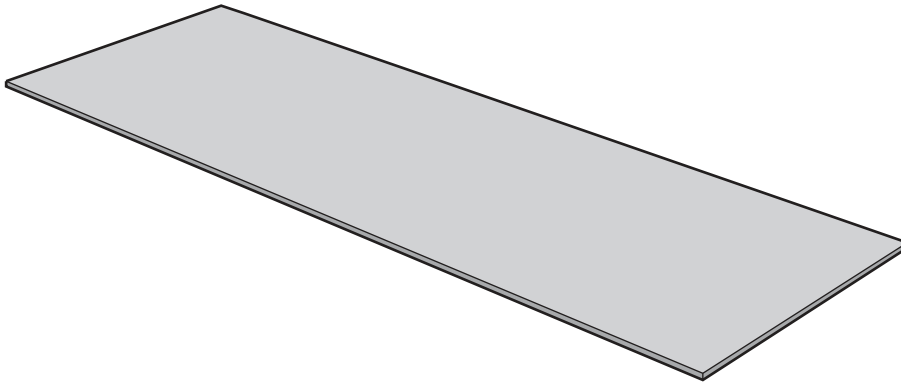

sheet of modelling material (foamboard)

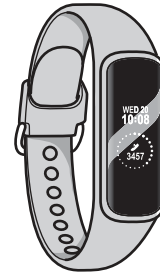

'ACTIVE' sports watch (strap Ø70)

Fig. 8.1

- (a) Use notes and sketches to **develop** a design for a point of sale (POS) display, for the 'ACTIVE' sports watch, made from the sheet of modelling material (foamboard). [20]
- (b) Use notes and sketches to **develop** a design for a leaflet to promote the use of the 'ACTIVE' sports watch in fitness training. [20]
- (c) Use notes and sketches to **develop** a design for a holder for 20 copies of the leaflet designed in **part (b)**.
The holder must be attached to the point of sale (POS) display designed in **part (a)**. [20]
- (d) Produce a pictorial (3D) rendered drawing of the completed point of sale display (POS) which shows all the features that you have designed in **parts (a) – (c)**. [20]

- 9 Fig. 9.1 shows the parts of a solar powered circulatory system for a garden water feature. The water is pumped out of the tray, through the hose to the feature and then falls back into the tray.

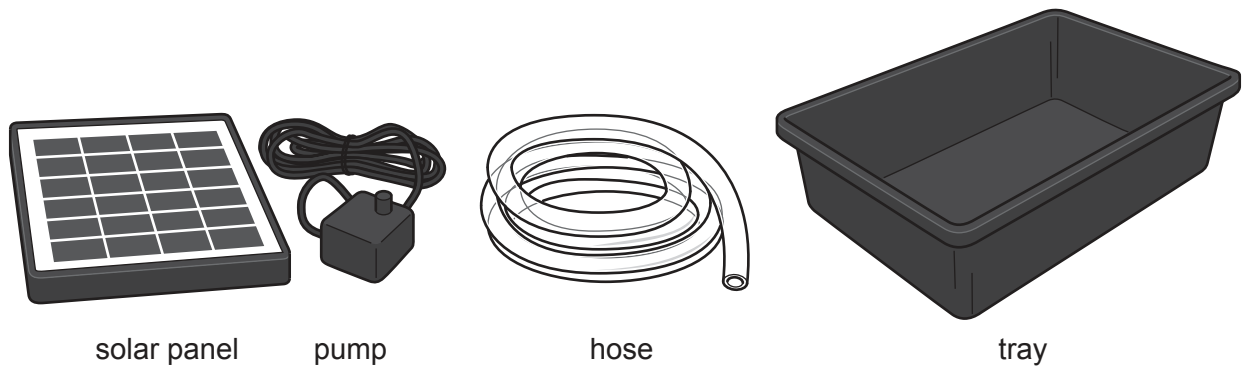

Fig. 9.1

- (a) Use notes and sketches to **develop** a design for a garden water feature that uses the flow of water to produce movement. [20]
- (b) Use notes and sketches to **develop** a design for a device that attaches to the hose to adjust the flow of water. [20]
- (c) Use notes and sketches to **develop** a design for a method of mounting the solar panel on a wall so that it can be adjusted to face the sun. [20]
- (d) Produce a pictorial (3D) rendered drawing of the complete garden feature which shows all the features that you have designed in **parts (a) – (c)**. [20]

BLANK PAGE

Permission to reproduce items where third-party owned material protected by copyright is included has been sought and cleared where possible. Every reasonable effort has been made by the publisher (UCLES) to trace copyright holders, but if any items requiring clearance have unwittingly been included, the publisher will be pleased to make amends at the earliest possible opportunity.

To avoid the issue of disclosure of answer-related information to candidates, all copyright acknowledgements are reproduced online in the Cambridge Assessment International Education Copyright Acknowledgements Booklet. This is produced for each series of examinations and is freely available to download at www.cambridgeinternational.org after the live examination series.

Cambridge Assessment International Education is part of Cambridge Assessment. Cambridge Assessment is the brand name of the University of Cambridge Local Examinations Syndicate (UCLES), which is a department of the University of Cambridge.